

# Specification

**Acrich2 – MR**

**100V 4.3W**

**SMJP-1V04W1P1**

<b>SSC</b>		<b>Customer</b>
Drawn	Approval	Approval

## Acrich2 - 100V 4.3W MR

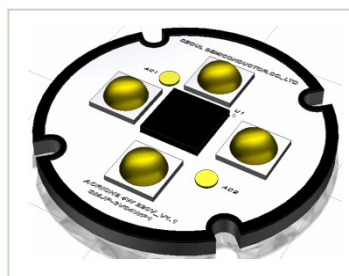

### Description

The Acrich 2 series, which are designed for AC drive (or operation), do not need the standard converter essential for a conventional general lighting product.

The modules also have a high power factor which can contribute to high energy savings in many lighting applications.

Since there is no need for a converter, the Acrich 2 series life-time can be estimated

closer to the LED because it is not as dependent on the other electronics in the system.

It also allows for better utilization of space without the converter.

\* The appearance and specifications of the product can be changed for improvement without notice.

## Acrich2

### Features

- Connect using a AIC directly to AC power
- High Power Efficiency
- High Power Factor
- Low THD
- Long Life Time
- Simplest BOM
- Miniaturization
- Lead Free product
- RoHS compliant

### Applications

- Bulb light
- Down light
- Factory Ceiling light
- Industrial Light

## [ Contents ]

<b>1. Characteristics</b>	<b>-----4</b>
<b>2. Thermal Resistance</b>	<b>-----6</b>
<b>3. Color spectrum</b>	<b>-----7</b>
<b>4. Power characteristics</b>	<b>-----7</b>
<b>5. Radiation pattern</b>	<b>-----8</b>
<b>6. Color &amp; Binning</b>	<b>-----9</b>
<b>7. Marking</b>	<b>-----11</b>
<b>8. Outline dimensions</b>	<b>-----11</b>
<b>9. Circuit Drawing</b>	<b>-----12</b>
<b>10. Packing</b>	<b>-----13</b>
<b>11. Usage precautions</b>	<b>-----14</b>
<b>12. Handling of silicone resin for LEDs</b>	<b>-----14</b>
<b>13. Handling with regards to static electricity</b>	<b>--15</b>
<b>14. Storage before use</b>	<b>-----15</b>

## 1. Characteristics

### 1-1-1. Electro-Optical characteristics of SMJP-1V04W1P1-G rank

Parameter	Symbol	Value			Unit
		Min	Typ	Max	
Luminous Flux [2]	$\Phi_V$ [3]	220	245	-	lm
Correlated Color Temperature [4]	CCT	2900	3000	3200	K
CRI	$R_a$	80	-	-	-
Operating Voltage [5]	$V_{opt}$	100			V[RMS]
Power Dissipation	$P_D$	4.0	4.3	4.6	W
Operating Frequency	Freq	50 / 60			Hz
Power Factor	PF	Over 0.95			-
View Angle	$2\theta$ 1/2	120			deg.

### 1-1-2. Electro-Optical characteristics of SMJP-1V04W1P1-H rank

Parameter	Symbol	Value			Unit
		Min	Typ	Max	
Luminous Flux [2]	$\Phi_V$ [3]	220	245	-	lm
Correlated Color Temperature [4]	CCT	2600	2700	2900	K
CRI	$R_a$	80	-	-	-
Operating Voltage [5]	$V_{opt}$	100			V[RMS]
Power Dissipation	$P_D$	4.0	4.3	4.6	W
Operating Frequency	Freq	50 / 60			Hz
Power Factor	PF	Over 0.95			-
View Angle	$2\theta$ 1/2	120			deg.

**1-2 Absolute Maximum Ratings**

Parameter	Symbol	Value	Unit
<b>Max. Voltage</b>	$V_{opt}$	120	V[RMS]
<b>Power Dissipation</b>	$P_d$	5.7	W
<b>Operating Temperature</b>	$T_{opr}$	-30 ~ 85	°C
<b>Storage Temperature</b>	$T_{stg}$	-40 ~ 100	°C
<b>ESD Sensitivity</b>	-	± 4,000V HBM	-

\* Notes :

- [1] At 100V RMS,  $T_a=25^{\circ}C$
- [2] Acrich 2 series maintain the tolerance of  $\pm 10\%$  on flux and power measurements.
- [3]  $\Phi_v$  is the total luminous flux output measured with an integrated sphere.
- [4] Correlated Color Temperature is derived from the CIE 1931 Chromaticity diagram.
- [5] Operating Voltage doesn't indicate the maximum voltage which customers use but means tolerable voltage according to each country's voltage variation rate.  
It is recommended that the solder pad temperature should be below  $70^{\circ}C$ .

## 2. Thermal Resistance

Part	Package power dissipation [W]	Maximum Junction Temp[ °C]	R $\theta_{j-s}$ [ °C/W]
Acrich2 LED	AZ4 Max. 1.2	125	5.7
Acrich2 IC	Max. 1.2	125	16.4

The Acrich2 LED has a thermal resistance of 27degC/W from junction to the LED lead.

The maximum junction temperature of Acrich2 LED package is 125degC, therefore the maximum lead temperature  $T_{s\_max}$  is

$$T_{s\_max} = T_{j\_max} - (R\theta_{j-s} * P_D)$$

$$= 125^{\circ}\text{C} - (5.7^{\circ}\text{C/W} * 1.2\text{W}) = 118.2^{\circ}\text{C}$$

Although this is the maximum lead temperature, it is recommended to keep the lead temperature under 70degC

The Acrich2 IC has a 16.4degC/W thermal resistance from junction to the top surface.

The maximum junction temperature ( $T_{t\_max}$ ) of the IC is 125degC, therefore the maximum temperature of the top of the IC is

$$T_{t\_max} = T_{j\_max} - (\psi_{j-t} * P_D)$$

$$= 125^{\circ}\text{C} - (16.4^{\circ}\text{C/W} * 1.2\text{W}) = 105.3^{\circ}\text{C}$$

### 3. Color spectrum

Relative Spectral Power Distribution at Ta=25°C, 3000K

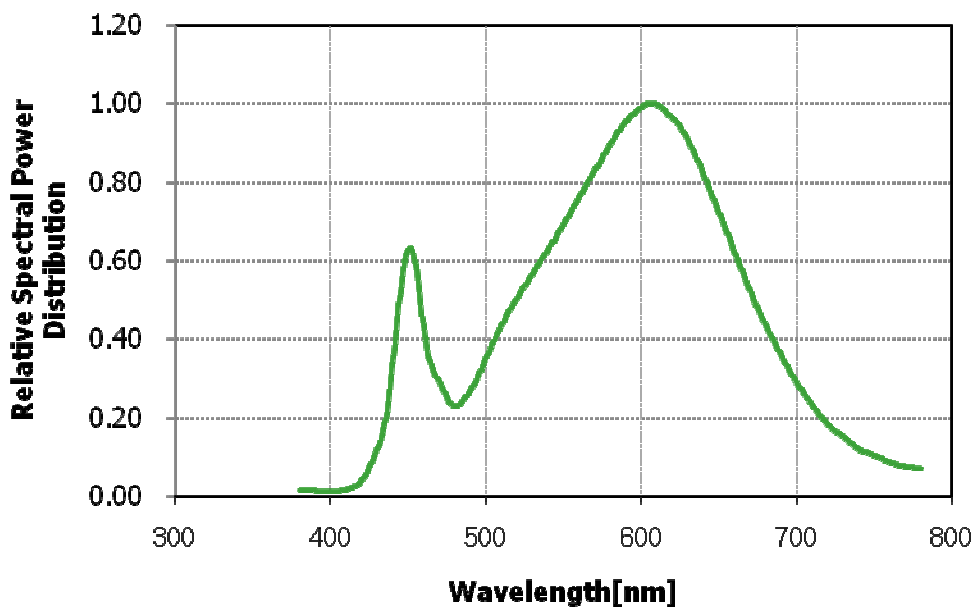

### 4. Power characteristic

Relative Power Distribution vs. Voltage at Ta=25°C

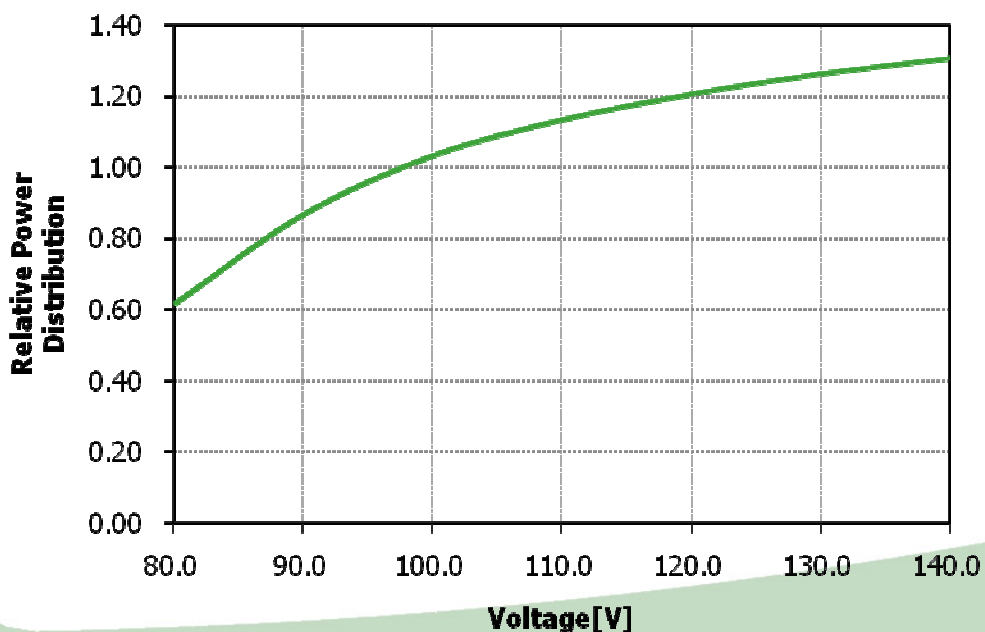

**Relative Luminous flux vs. Forward Voltage, Ta=25°C**

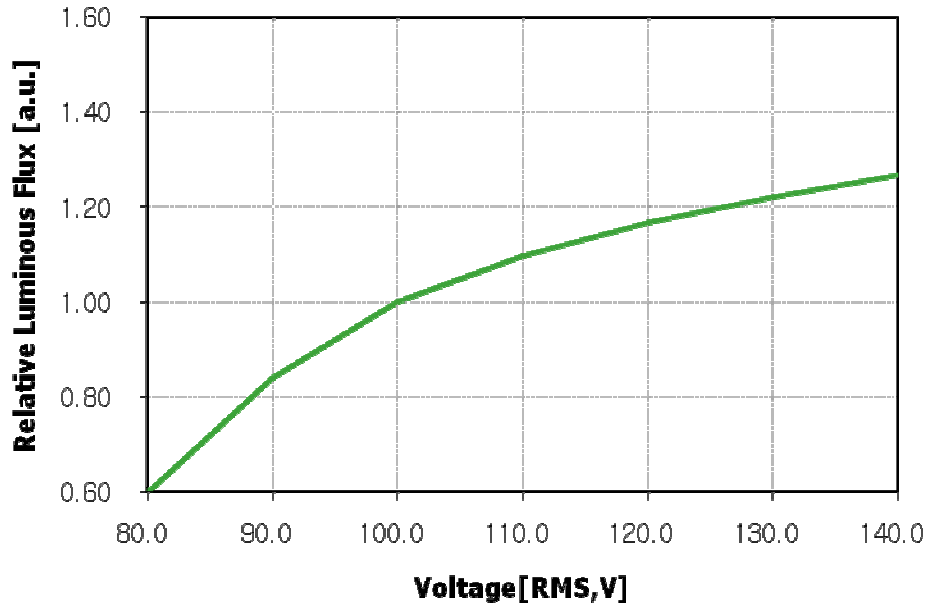

### 5. Radiation Pattern

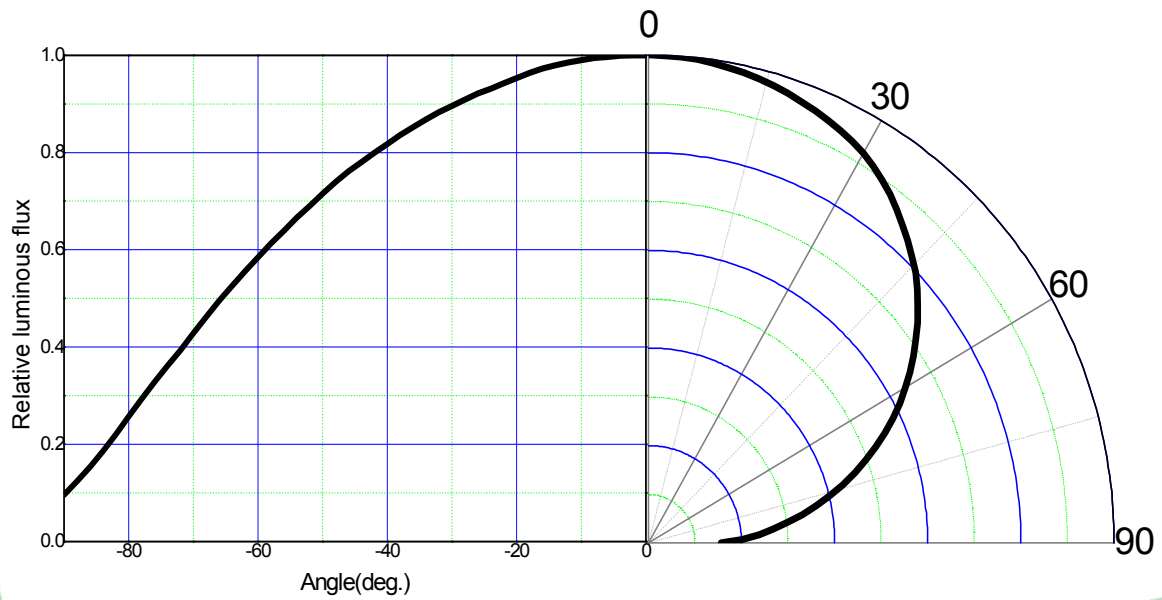



## 6. Color & Binning

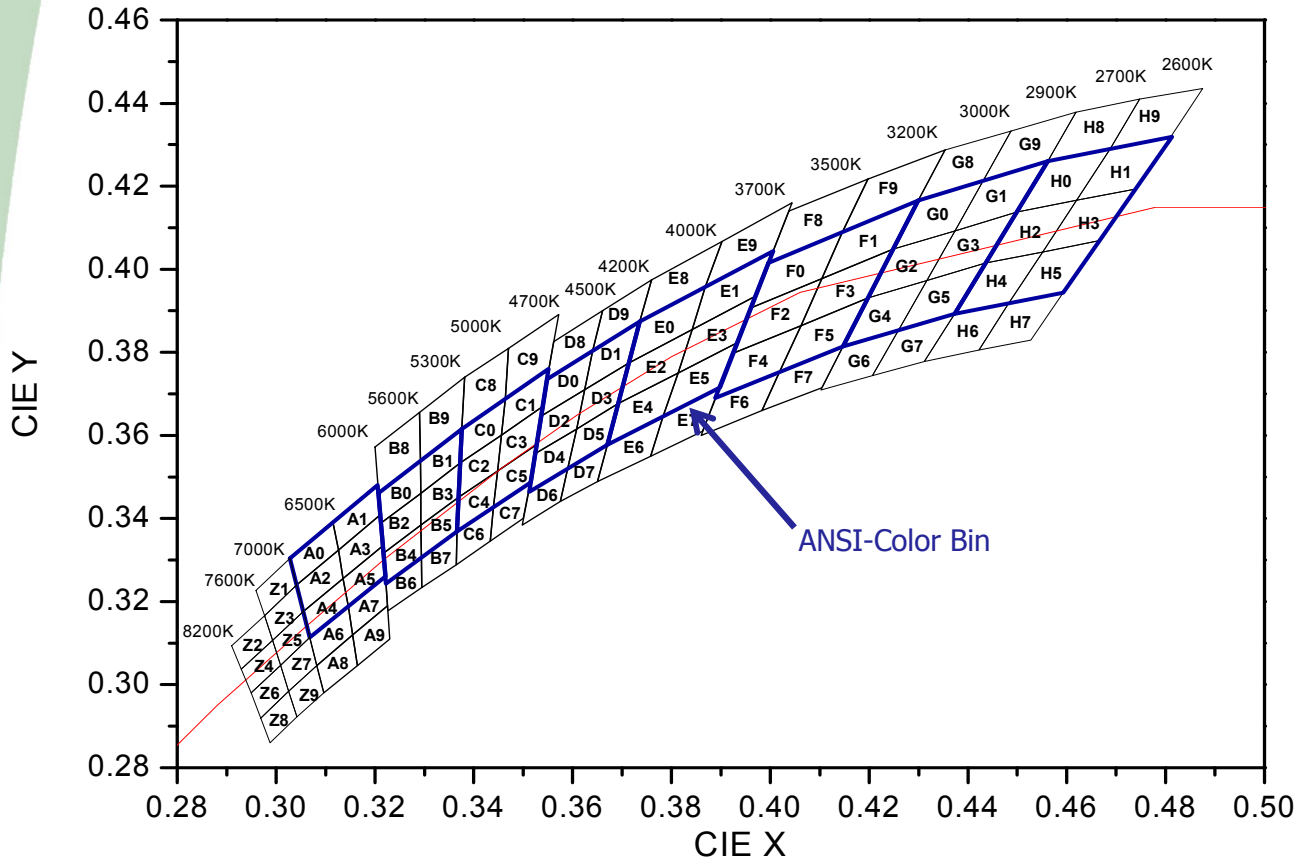

\*Notes : For more detailed information on Acrich binning see the "Acrich Binning and Labeling" document at [www.Acrich.com](http://www.Acrich.com)

\* Measurement Uncertainty of the Color Coordinates :  $\pm 0.01$

▷ **COLOR RANK**

Rank	Bin	CIE X	CIE Y	Bin	CIE X	CIE Y	Bin	CIE X	CIE Y						
G	G0	X1	0.4299	Y1	0.4165	G1	X1	0.4430	Y1	0.4212	G2	X1	0.4248	Y1	0.4048
		X2	0.4248	Y2	0.4048		X2	0.4374	Y2	0.4093		X2	0.4198	Y2	0.3931
		X3	0.4374	Y3	0.4093		X3	0.4499	Y3	0.4138		X3	0.4317	Y3	0.3973
		X4	0.4430	Y4	0.4212		X4	0.4562	Y4	0.4260		X4	0.4374	Y4	0.4093
	G3	X1	0.4374	Y1	0.4093	G4	X1	0.4198	Y1	0.3931	G5	X1	0.4317	Y1	0.3973
		X2	0.4317	Y2	0.3973		X2	0.4147	Y2	0.3814		X2	0.4259	Y2	0.3853
		X3	0.4436	Y3	0.4015		X3	0.4259	Y3	0.3853		X3	0.4373	Y3	0.3893
		X4	0.4499	Y4	0.4138		X4	0.4317	Y4	0.3973		X4	0.4436	Y4	0.4015

Rank	Bin	CIE X	CIE Y	Bin	CIE X	CIE Y	Bin	CIE X	CIE Y						
H	H0	X1	0.4562	Y1	0.4260	H1	X1	0.4687	Y1	0.4289	H2	X1	0.4499	Y1	0.4138
		X2	0.4499	Y2	0.4138		X2	0.4620	Y2	0.4166		X2	0.4436	Y2	0.4015
		X3	0.4620	Y3	0.4166		X3	0.4740	Y3	0.4194		X3	0.4551	Y3	0.4042
		X4	0.4687	Y4	0.4289		X4	0.4810	Y4	0.4319		X4	0.4620	Y4	0.4166
	H3	X1	0.4620	Y1	0.4166	H4	X1	0.4436	Y1	0.4015	H5	X1	0.4551	Y1	0.4042
		X2	0.4551	Y2	0.4042		X2	0.4373	Y2	0.3893		X2	0.4483	Y2	0.3919
		X3	0.4666	Y3	0.4069		X3	0.4483	Y3	0.3919		X3	0.4593	Y3	0.3944
		X4	0.4740	Y4	0.4194		X4	0.4551	Y4	0.4042		X4	0.4666	Y4	0.4069

## 7. Marking

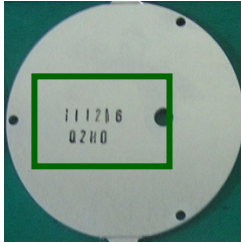

**YYMMDD: Production Date**  
**XXXX – LED PKG Flux Rank / Color Bin Rank**

## 8. Outline dimensions

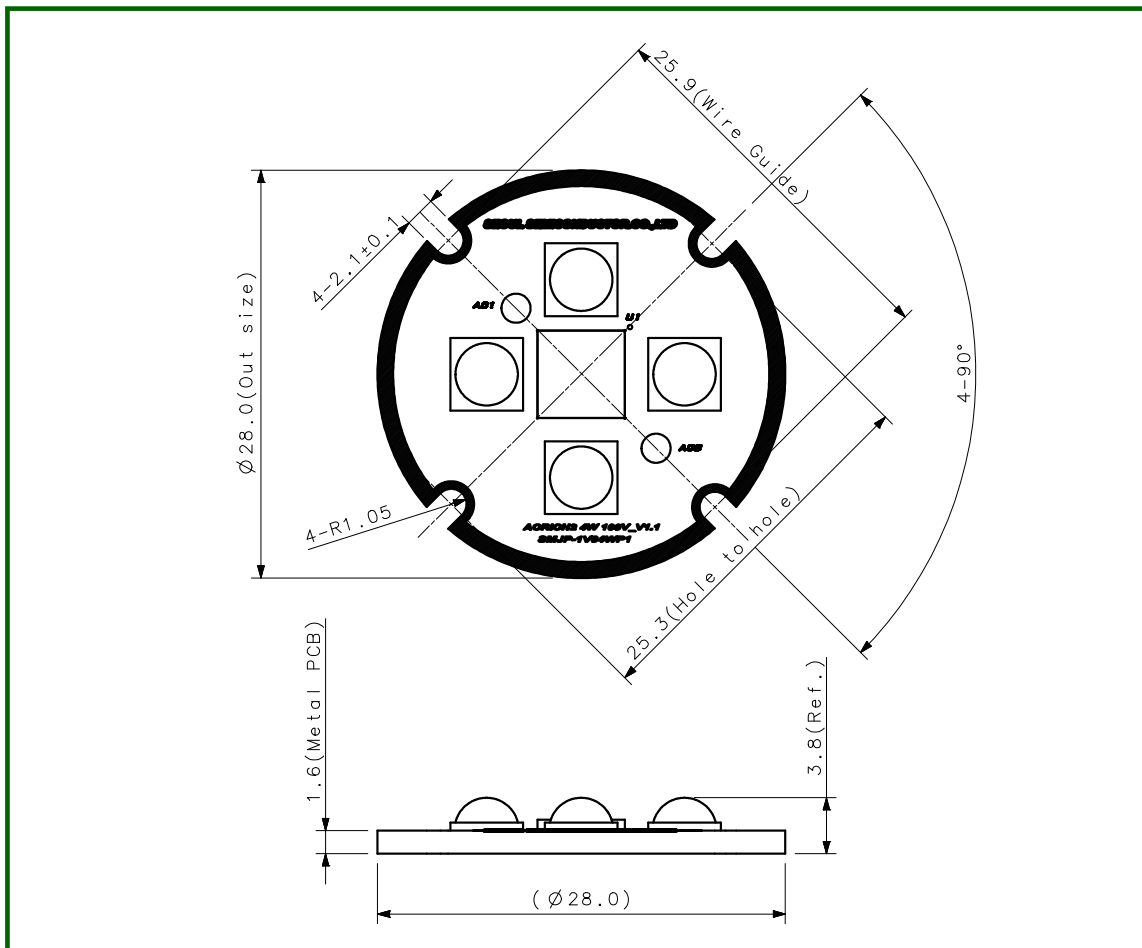

\* Notes :

- [1] All dimensions are in millimeters. (Tolerance :  $\pm 0.2$ )
- [2] Scale : none
- [3] The appearance and specifications of the product may be changed for improvement without notice

## 9. Circuit Drawing

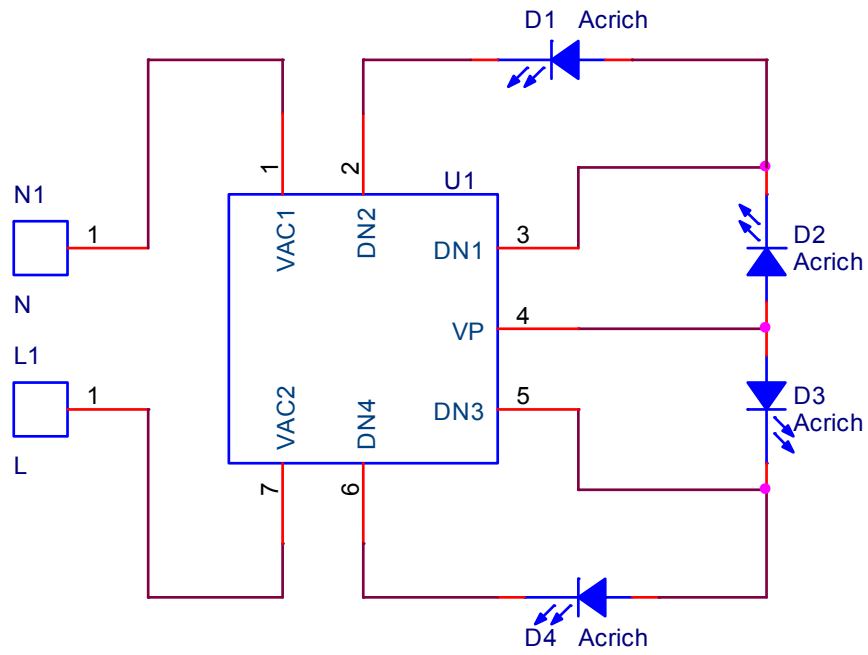

## 10. Packing

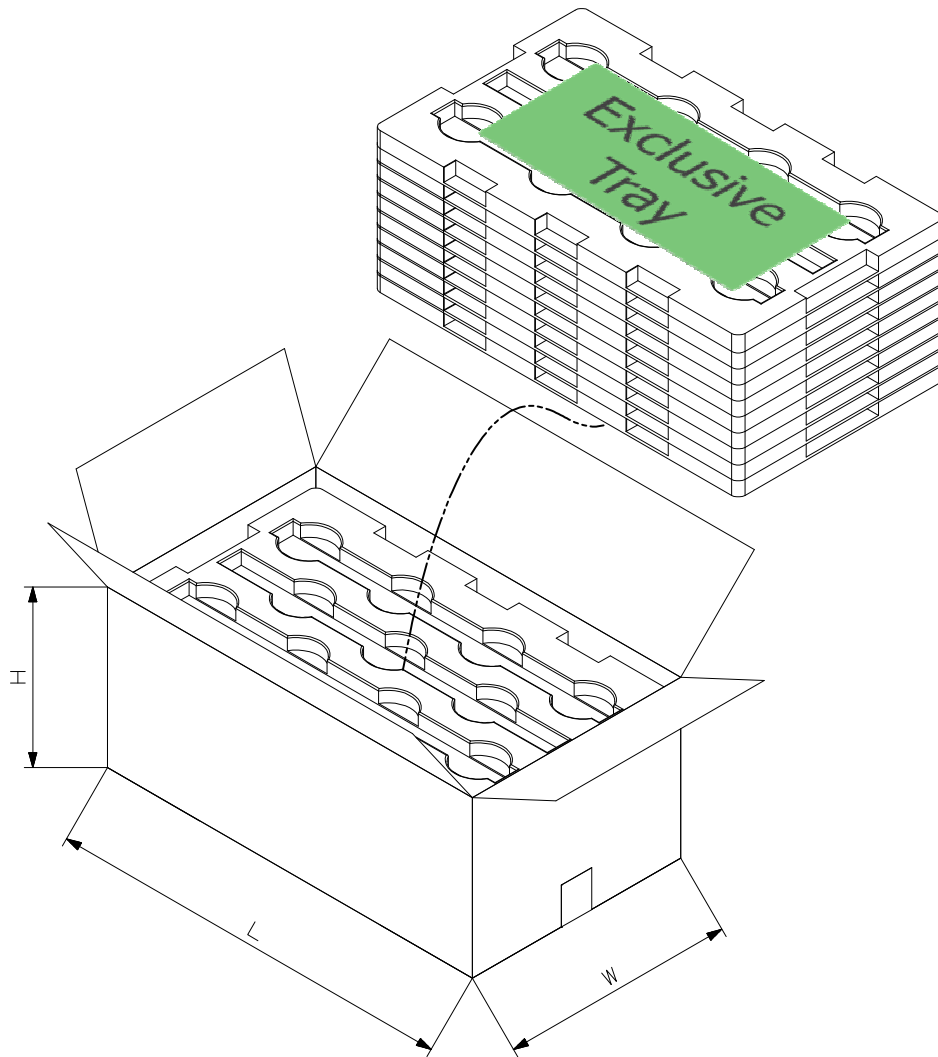

◦ **1Box : 100 PCS per tray x Max.10 layer = Max.1000 PCS**

**about 6kg**

◦ **Box size( L x W x H ) = 590 x 330 x 260**

## 11. Usage precautions

- Please review the Acrich2 Module Application Note for protective circuitry component usage.
- Please note, the Acrich products run on high voltage so use caution when near the the device which the circuit is active.
- DO NOT touch any of the circuit board, components or terminals with body or metal while circuit is active.
- Please do not add or change wires while Acrich circuit is active
- The appearance and specifications of the product may be modified for improvement without notice.
- Long time exposure of sunlight or occasional UV exposure will cause lens discoloration.
- Please do not use adhesives to attach the LED that outgas organic vapor.
- Please do not use together with the materials containing Sulfur
- Please do not assemble under the condition of moisture and oxidizing gas in the air(Cl, H<sub>2</sub>S,NH<sub>3</sub>,SO<sub>2</sub>,NOX,etc)

## 12. Handling of silicone resin for LEDs

- Acrich series is encapsulated with silicone resin for high optical efficiency.
- Please do not touch the silicone resin area with sharp objects such as pincette(tweezers).
- Finger prints on silicone resin area may affect the performance.
- Please store LEDs in covered containers as it is dust sensitive.
- Excessive force more than 3000gf to the silicone lens can result in fatal or permanent damage with LEDs.
- Please do not cover the silicone resin area with any other resins such as epoxy, urethane, etc.

### 13. Handling with regards to static electricity

- The Acrich2 modules use an integrated circuit (IC) which can be damaged when exposed to static electricity. Please handle using equipment that prevents static electricity. Do not touch unless ESD protection is used.
- The Acrich2 modules should also not be installed in end equipment with out ESD protection.

### 14. Storage before use

- Do not impact or place pressure on this product because even a small amount of pressure can damage the product. The product should also not be placed in high temperatures, high humidity or direct sunlight since the device is sensitive to these conditions.

(1) Please, confirm the lists below, when storing it in a long term.

- \* It should be stored in the anti-static bag that Seoul-Semiconductor packed without opening it.
- \* If you opened it in order to prevent humidity, you should seal it and not let the air and humidity into the bag.